

# Quick Start

## **Savi™ Office WO100 Wireless Headset System**

**Quick Start Guide**

**Guide de démarrage rapide**

**Guía de inicio rápido**

**Guia de Início Rápido**

**1**

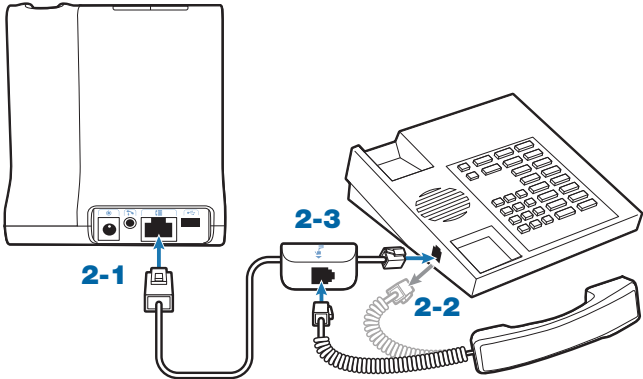
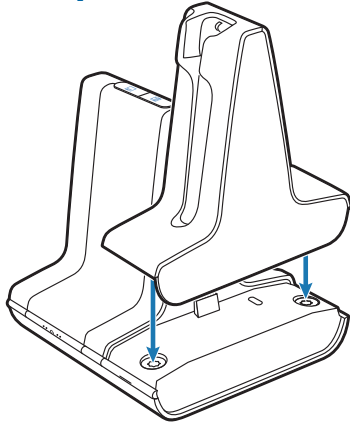

3-2

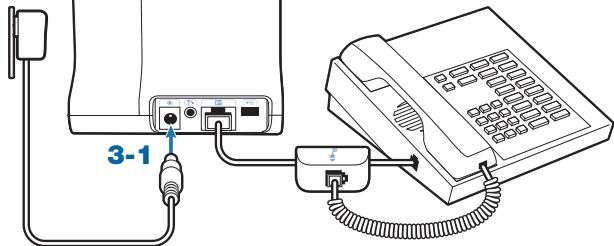

3-1

4

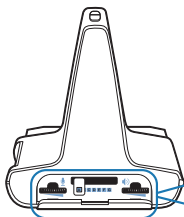
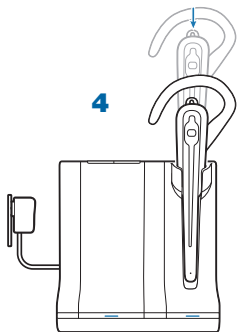

5-2

5-7

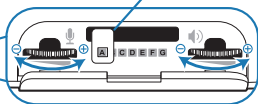

5-2

6-6

5-2

6-5

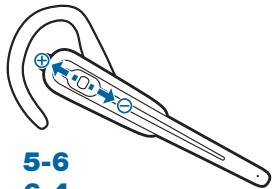

5-6

6-4

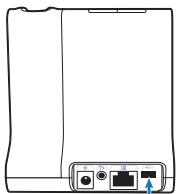

7-1

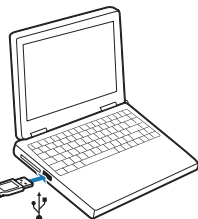

7-2

## Savi WO1 Base

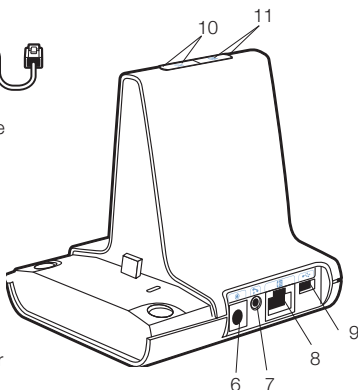
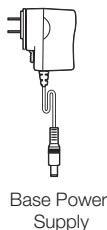
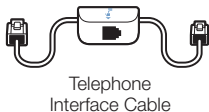
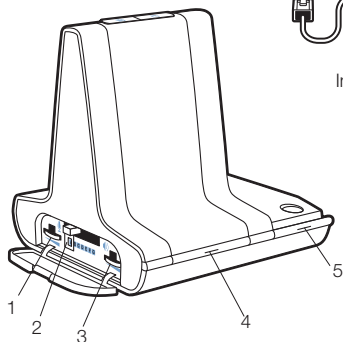

1. Desk Phone Speaking Volume
2. Configuration Switch
3. Desk Phone Listening Volume
4. Subscription Button and Indicator Light
5. Indicator Light
6. Power Jack
7. Handset Lifter Jack
8. Telephone Interface Cable Jack
9. USB Port
10. Desk phone Talk Button and Indicator Light
11. PC Talk Button and Indicator Light

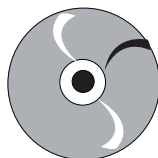
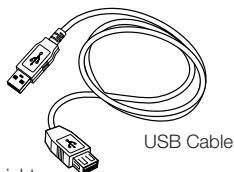

CD includes:

- PerSono® Suite Software
- Animated Setup Guide
- Complete User Guide

## Savi WH100/WH110 Headset

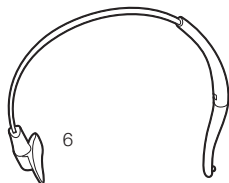
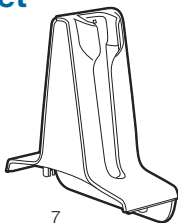
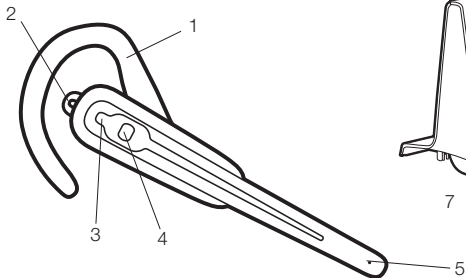

1. Earloop
2. Ear Tab
3. Indicator Light
4. Call Control Button (also controls volume, mute and switching functions)
5. Microphone
6. Headband
7. Charge Cradle
8. Extra Ear Tab
9. Foam Ear Cushions

# Welcome

Congratulations on purchasing your new Plantronics product. This Quick Start Guide contains instructions for setting up the Savi Office WO100 (WO1™ Base + WH100/WH110™ Headset) Wireless Headset System. Please refer to the separate **safety instructions** for important product safety information prior to installation or use of the product.

## System Requirements

The minimum system requirements for Savi Office are as follows:

- Supported Operating Systems: Windows XP, Windows Vista
- Processor: 400 MHz Pentium processor or equivalent (Minimum); 1 GHz Pentium processor or equivalent (Recommended)
- RAM: 96 MB (Minimum); 256 MB (Recommended)
- Hard Disk: 280 MB (Minimum); 500 MB (Recommended)
- Display: 800 x 600, 256 colours (Minimum); 1024 x 768 high colour, 32-bit (Recommended)
- Internet Explorer V6 or better must be on the user's system (Required)

**We highly recommend that you refer to the CD for Animated Set Up instructions and the complete User Guide.**

## Safety Instructions

 Do not use headphones / headsets at high volumes for an extended period of time. Doing so can cause hearing loss. Always listen at moderate levels. See [www.plantronics.com/healthandsafety](http://www.plantronics.com/healthandsafety) for more information on headsets and hearing.

# Setting Up the Savi Office WO100 System

## 1. Attaching Charge Cradle to Base

Connect the headset charge cradle to the base. Push firmly on the cradle until the cradle snaps into place.

## 2. Connecting Base to Desk Phone

- 2-1. Connect the telephone interface cable to the telephone interface cable jack on the base.
- 2-2. After disconnecting the handset coil cord from the desk phone, connect the telephone interface cable to the now open handset port on the desk phone.
- 2-3. Connect the handset coil cord to the telephone interface cable junction box.

## 3. Connecting Power Supply to Base

- 3-1. Connect the base power supply into the power jack on the base.
- 3-2. Connect the power supply to outlet.

## 4. Docking and Charging Headset

Gently push the headset into the charge cradle. Charge for at least 20 minutes prior to the first use. A full charge takes 3 hours.

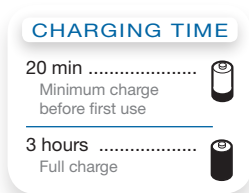

## 5. Checking Configuration

- 5-1. Set volume on desk phone to mid-range.
- 5-2. On the base, ensure the configuration switch is set to "A" and the desk phone speaking volume and desk phone listening volume are both set to 3.

**NOTE** For most phones, these factory default settings will sound the best.

- 5-3. With your headset on, press the call control button on headset.
- 5-4. Remove the headset from desk phone cradle.

- 5-5. Listen for a dial tone. If the dial tone sounds clear, press the call control button on headset and continue with **Step 6. Making a Test Call with Desk Phone**.
- 5-6. If the dial tone is too loud or too soft, adjust the headset volume level.
- 5-7. If the dial tone still does not sound clear, adjust the configuration switch until the dial tone sounds the best.

**NOTE** Multiple settings might work with your phone; however, only one is the optimal position.

- 5-8. Press the call control button on the headset and return the handset to the cradle to complete configuration.

## 6. Making a Test Call with Desk Phone

- 6-1. With your headset on, press the call control button on headset.
- 6-2. Remove the handset from desk phone cradle.
- 6-3. Dial the number using your desk phone.
- 6-4. If needed, adjust the listening volume on the headset.
- 6-5. If the listening volume is still too loud or too soft, adjust the desk phone listening volume on the base.
- 6-6. If the speaking volume is too loud or too soft for your listener, adjust the desk phone speaking volume on the base.
- 6-7. Press the call control button on the headset and return the handset to the cradle to complete the test call.

## 7. Connecting to the PC

- 7-1. Connect the USB cable to the USB port on the back of the base.
- 7-2. Connect the other end of the USB cable to the USB port on the PC.
- 7-3. Insert the CD and install the PerSono Suite software. Follow the installation instructions shown on your PC.

## 8. Making a Test Call with PC

- 8-1. Ensure the PerSono Suite software is running on your PC.
- 8-2. With your headset on, press the PC talk button on the base.
- 8-3. Dial the number using your softphone application.
- 8-4. Adjust listening and speaking volume using your softphone application and/or "sound and audio devices" in your PC control panel.
- 8-5. You can fine tune the listening volume on the headset.
- 8-6. To end the test call, press the call control button on the headset.

Please refer to the complete User Guide located on the CD for further details on how to use your Savi Office WO100 Professional Wireless Headset System.

## Base Savi WO1

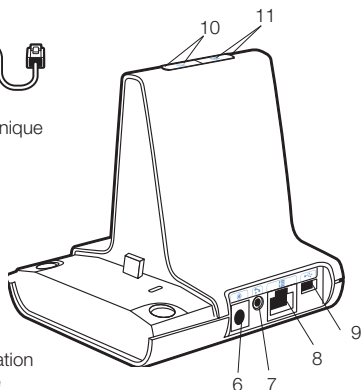
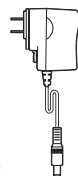
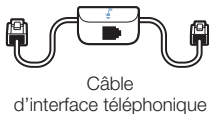
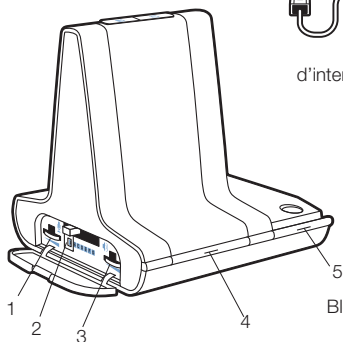

1. Volume d'émission du téléphone
2. Commutateur de configuration
3. Volume de réception du téléphone
4. Bouton d'association et voyant
5. Voyant de charge
6. Prise d'alimentation
7. Prise du décrocheur de combiné
8. Prise de câble d'interface téléphonique
9. Port USB
10. Bouton de conversation par téléphone et voyant
11. Bouton de conversation par ordinateur et voyant

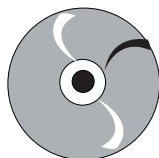
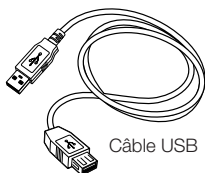

Contenu du CD :

- Logiciel PerSono®
- Guide de configuration animé
- Guide de l'utilisateur complet

## Micro-casque Savi WH100/WH110

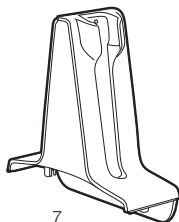
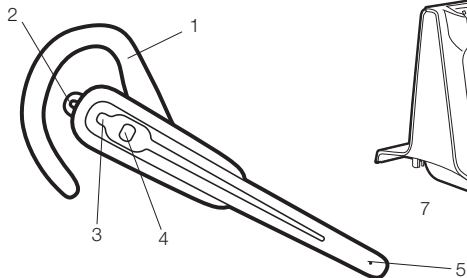

1. Contour d'oreille
2. Embout
3. Voyant
4. Bouton de contrôle des appels (contrôle aussi le volume et les fonctions de sourdine et de commutation)
5. Microphone
6. Serre-tête
7. Chargeur
8. Embout pour oreille supplémentaire
9. Coussinets en mousse



# Bienvenue

Félicitations pour votre nouveau produit Plantronics. Ce guide de démarrage rapide contient les directives d'installation de votre système sans fil Savi Office WO100 (base WO1™ et micro-casque WH100/WH110™). Veuillez lire les **consignes de sécurité** fournies séparément avant d'installer ou d'utiliser le produit. Elles contiennent des renseignements importants relatifs à la sécurité.

## Configuration système requise

La configuration système requise pour Savi Office est la suivante :

- Systèmes d'exploitation compatibles : Windows XP et Windows Vista
- Processeur : 400 MHz (minimum); 1 GHz (recommandé)
- Mémoire : 96 Mo (minimum); 256 Mo (recommandé)
- Disque dur : 280 Mo (minimum); 500 Mo (recommandé)
- Affichage : 800 x 600, 256 couleurs (minimum); 1 024 x 768, couleurs 32 bits (recommandé)
- Internet Explorer version 6

**Nous vous recommandons fortement de vous reporter aux instructions du guide de configuration animé et du guide de l'utilisateur complet sur le CD.**

## Renseignements sur la sécurité

 Attention : N'utilisez pas les casques et micro-casques à volume élevé sur de longues périodes. Cela pourrait provoquer des problèmes d'audition. Conservez toujours un niveau d'écoute modéré. Consultez le site [www.plantronics.com/healthandsafety](http://www.plantronics.com/healthandsafety) pour obtenir de plus amples renseignements sur les micro-casques et l'audition.

# Installation du Savi Office WO100

## 1. Connexion du chargeur à la base

Connectez le chargeur à la base. Appuyez fermement sur le chargeur jusqu'à ce qu'il soit bien en place.

## 2. Connexion de la base au téléphone

- 2-1. Branchez le câble d'interface dans la prise d'interface de la base.
- 2-2. Débranchez le câble enroulé de combiné sur le téléphone, puis branchez le câble d'interface dans cette même prise sur le téléphone.
- 2-3. Branchez le câble enroulé de combiné dans la boîte de jonction du câble d'interface.

## 3. Branchement du bloc d'alimentation

- 3-1. Branchez la mini-fiche du bloc dans la prise d'alimentation de la base.
- 3-2. Branchez la fiche dans une prise électrique.

## 4. Recharge du micro-casque

Poussez doucement le micro-casque dans le chargeur. Chargez le micro-casque pendant au moins 20 minutes avant de l'utiliser pour la première fois. Une charge complète dure 3 heures.

### TEMPS DE CHARGE

20 min .....   
Charge minimale avant  
la première utilisation

3 heures .....   
Charge complète

## 5. Vérification de la configuration

- 5-1. Sur le téléphone, réglez le volume à la moitié.
- 5-2. Assurez-vous que le sélecteur de configuration de la base est positionné sur « A » et que les volumes d'émission et de réception du téléphone sont réglés sur 3.

**REMARQUE :** sur la plupart des téléphones, ces réglages par défaut permettent d'obtenir la meilleure qualité sonore.

- 5-3. Mettez le micro-casque, puis appuyez sur le bouton de contrôle des appels.
- 5-4. Soulevez le combiné du téléphone.

- 5-5. Vous devriez entendre la tonalité. Si la tonalité est claire, appuyez sur le bouton de contrôle des appels du micro-casque, puis passez à l'étape 6. **Appel de test avec le téléphone.**
- 5-6. Si la tonalité est trop forte ou trop faible, réglez le volume du micro-casque.
- 5-7. Si, malgré vos réglages, la tonalité n'est toujours pas clairement audible, changez la position du sélecteur de configuration jusqu'à ce qu'elle vous convienne.

**REMARQUE :** même si plusieurs réglages peuvent fonctionner avec le téléphone, un seul est optimal.

- 5-8. Pour terminer la configuration, appuyez sur le bouton de contrôle des appels du micro-casque et reposez le combiné sur le téléphone.

## 6. Appel de test avec le téléphone

- 6-1. Mettez le micro-casque, puis appuyez sur le bouton de contrôle des appels.
- 6-2. Soulevez le combiné du téléphone.
- 6-3. Composez le numéro sur le téléphone.
- 6-4. Au besoin, réglez le volume de réception sur le micro-casque.
- 6-5. S'il est encore trop fort ou trop faible, ajustez-le sur la base du téléphone.
- 6-6. Si le volume d'émission ne convient pas à votre interlocuteur, réglez-le sur la base du téléphone.
- 6-7. Pour terminer l'appel de test, appuyez sur le bouton de contrôle des appels du micro-casque et reposez le combiné sur le téléphone.

## 7. Connexion à l'ordinateur

- 7-1. Branchez une extrémité du câble USB dans le port USB à l'arrière de la base.
- 7-2. Branchez l'autre extrémité dans un port USB de l'ordinateur.
- 7-3. Insérez le CD dans le lecteur optique de l'ordinateur et installez le logiciel PerSono. Suivez les instructions affichées.

## 8. Appel de test avec l'ordinateur

- 8-1. Démarrez PerSono Suite sur l'ordinateur.
- 8-2. Mettez le micro-casque, puis appuyez sur le bouton de conversation par PC sur la base.
- 8-3. Composez le numéro de téléphone avec votre application de téléphonie.
- 8-4. Vous pouvez régler le volume d'émission et d'écoute avec l'application de téléphonie ou avec l'option Sons et périphériques audio du Panneau de configuration de Windows.
- 8-5. Vous pouvez ajuster le volume d'écoute sur le micro-casque.
- 8-6. Pour raccrocher, appuyez sur le bouton de contrôle des appels du micro-casque.

Pour plus de détails sur l'utilisation de votre système de micro-casque sans fil professionnel Savi Office WO100, consultez le guide de l'utilisateur sur le CD.

## Base Savi WO1

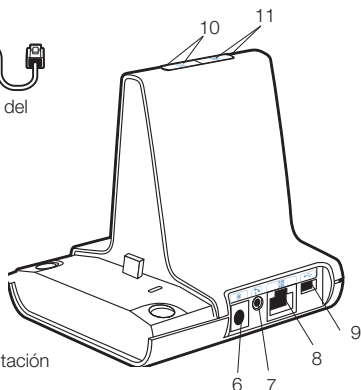
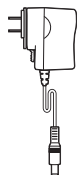
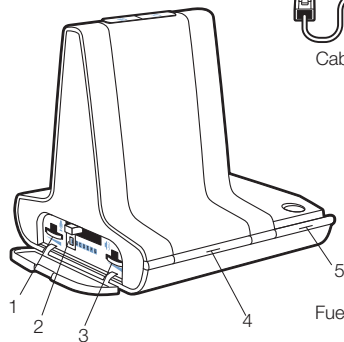

1. Volumen de conversación del teléfono de escritorio
2. Control de configuración
3. Volumen de escucha del teléfono de escritorio
4. Volumen de escucha del teléfono de escritorio
5. Luz indicadora de carga
6. Entrada de alimentación
7. Entrada del dispositivo para descolgar el teléfono
8. Entrada del cable de interfaz del teléfono
9. Puerto USB
10. Botón de conversación por el teléfono de escritorio
11. Botón de conversación por la PC y luz indicadora

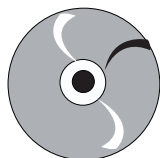
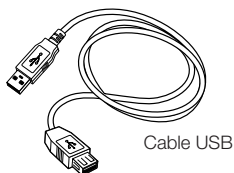

## Audífono Savi WH100/WH110

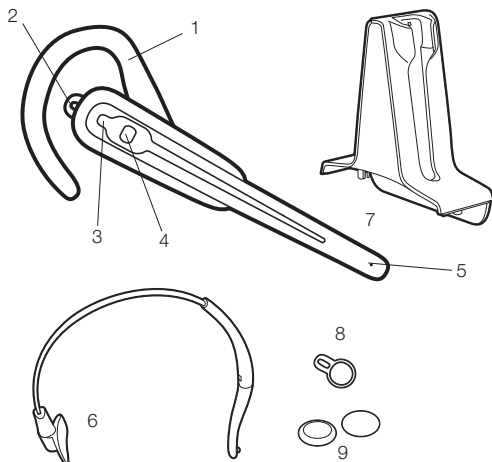

El CD incluye:

- Paquete de software PerSono®
- Guía animada de configuración
- Manual del usuario completo

1. Gancho
2. Lengüeta
3. Luz indicadora
4. Botón de control de llamadas (también controla las funciones de volumen, silencio y conmutación)
5. Micrófono
6. Diadema
7. Base de carga
8. Lengüeta adicional
9. Orejeras acolchadas

# Bienvenido

Felicidades por su compra de un nuevo producto Plantronics. Esta guía de inicio rápido contiene instrucciones para configurar el sistema de audífonos inalámbricos Savi Office WO100 (base WO1™ y audífonos WH100/WH110™). Antes de instalar o utilizar el producto, consulte las **instrucciones de seguridad** (aparte) para obtener información importante acerca de la seguridad del producto.

## Requisitos del sistema

Los requisitos mínimos del sistema para Savi Office son:

- Sistemas operativos compatibles: Windows XP, Windows Vista
- Procesador: procesador Pentium a 400 MHz o equivalente (mínimo); procesador Pentium a 1GHz o equivalente (recomendado)
- RAM: 96 MB (mínimo); 256 MB (recomendado)
- Disco duro: 280 MB (mínimo); 500 MB (recomendado)
- Pantalla: 800 x 600, 256 colores (mínimo); 1024 x 768 color de alta calidad, 32 bits (recomendado)
- Debe tener instalado Internet Explorer V6 o posterior en el sistema (necesario)

**Le recomendamos que consulte las instrucciones animadas de configuración y el manual del usuario completo incluidos en el CD.**

## Instrucciones de seguridad

 Advertencia: no use los auriculares o audífonos a un volumen alto durante periodos prolongados. Esto puede causar pérdida de audición. Use siempre un volumen moderado. Visite [www.plantronics.com/healthandsafety](http://www.plantronics.com/healthandsafety) donde encontrará más información acerca de los audífonos y la audición.

# Instalación del sistema Savi Office WO100

## 1. Conexión de la base de carga a la base

Conecte la base de carga del audífono a la base. Presione firmemente la base de carga contra la base hasta que encaje en su sitio.

## 2. Conexión de la base al teléfono de escritorio

- 2-1. Conecte el cable de interfaz del teléfono a la entrada correspondiente en la base.
- 2-2. Después de desconectar el cable espiral del auricular del teléfono de escritorio, conecte el cable de interfaz del teléfono a la entrada de auricular (ahora desocupada) del teléfono de escritorio.
- 2-3. Conecte el cable espiral del auricular a la caja de conexiones del cable de interfaz del teléfono.

## 3. Conexión de la fuente de alimentación a la base

- 3-1. Conecte la fuente de alimentación de la base a la entrada de alimentación de la base.
- 3-2. Conecte la fuente de alimentación a una toma de corriente.

## 4. Acoplamiento y carga del audífono

Presione suavemente el audífono en la base de carga. Cárguelo durante al menos 20 minutos antes de usarlo por primera vez. La carga completa tarda 3 horas.

### TIEMPO DE CARGA

20 min .....   
Carga mínima  
antes del primer uso

3 horas .....   
Carga completa

## 5. Comprobación de la configuración

- 5-1. Ajuste el volumen del teléfono de escritorio en un nivel intermedio.
- 5-2. En la base, compruebe que el control de configuración esté ajustado en "A", y que el volumen de conversación y el volumen de escucha del teléfono de escritorio estén ajustados en el nivel 3.

**NOTA** En la mayoría de los teléfonos, estos ajustes preconfigurados de fábrica producen un sonido óptimo.

- 5-3. Con el audífono puesto, presione el botón de control de llamadas del audífono.

- 5-4. Retire el auricular de la base del teléfono de escritorio.
- 5-5. Espere a escuchar el tono de marcar. Si escucha claramente el tono de marcar, presione el botón de control de llamadas del audífono y continúe con el paso 6.
- 5-6. Si el tono de marcar se escucha demasiado alto o demasiado bajo, ajuste el volumen del audífono.
- 5-7. Si el tono de marcar aún no suena claro, ajuste el control de configuración hasta obtener un sonido óptimo.

**NOTA** Puede haber varias configuraciones que funcionen con su teléfono; sin embargo, solo una es la posición óptima.

- 5-8. Presione el botón de control de llamadas del audífono y devuelva el auricular a la base para finalizar la configuración.

## 6. Realización de una llamada de prueba con el teléfono de escritorio

- 6-1. Con el audífono puesto, presione el botón de control de llamadas del audífono.
- 6-2. Retire el auricular de la base del teléfono de escritorio.
- 6-3. Marque el número en el teléfono de escritorio.
- 6-4. Si es necesario, ajuste el volumen de escucha en el audífono.
- 6-5. Si el volumen de escucha sigue siendo demasiado alto o demasiado bajo, ajuste el volumen de escucha del teléfono de escritorio en la base.
- 6-6. Si el volumen de conversación es demasiado alto o demasiado bajo para su interlocutor, ajuste el volumen de conversación del teléfono de escritorio en la base.
- 6-7. Presione el botón de control de llamadas del audífono y devuelva el auricular a la base para finalizar la llamada de prueba.

## 7. Conexión a la PC

- 7-1. Conecte el cable USB al puerto USB de la parte posterior de la base.
- 7-2. Conecte el otro extremo del cable USB al puerto USB de la PC.
- 7-3. Inserte el CD e instale el paquete de software PerSono . Siga las instrucciones de instalación que aparecen en la PC.

## 8. Realización de una llamada de prueba con la PC

- 8-1. Compruebe que el paquete de software PerSono se está ejecutando en su PC.
- 8-2. Con el audífono puesto, presione el botón de conversación por la PC de la base.
- 8-3. Marque el número con la aplicación de teléfono.
- 8-4. Ajuste el volumen de escucha y conversación con la aplicación de teléfono o en Dispositivos de sonido y audio, en el Panel de control de la PC.
- 8-5. Puede realizar un ajuste fino del volumen de escucha en el audífono.
- 8-6. Para terminar la llamada de prueba, presione el botón de control de llamadas del audífono.

Consulte el manual del usuario completo incluido en el CD para obtener más información acerca de cómo usar el sistema de audífonos inalámbricos profesionales Savi Office WO100.

## Base do Savi WO1

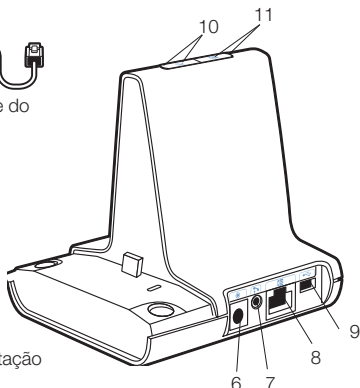
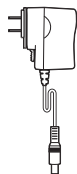
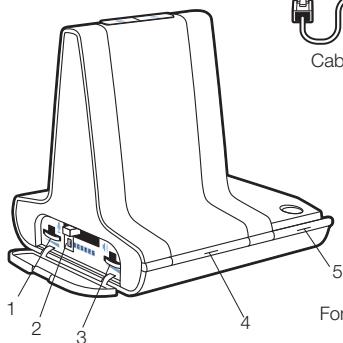

1. Volume de fala do telefone de mesa
2. Chave de configuração
3. Volume de audição do telefone de mesa
4. Botão de vinculação e luz indicadora
5. Luz indicadora de carga
6. Entrada de energia
7. Tomada do suporte de monofone
8. Entrada do cabo de interface do telefone
9. Porta USB
10. Botão de conversação e luz indicadora do telefone de mesa
11. Botão de conversação e luz indicadora do PC

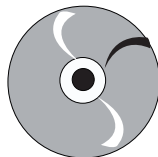
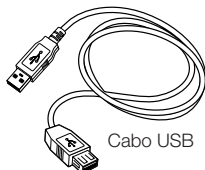

O CD inclui:

- Conjunto do software PerSono
- Guia de instalação animado
- Guia completo do usuário

## Headset Savi WH100/WH110

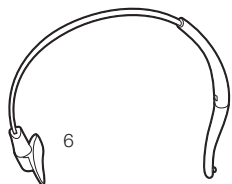
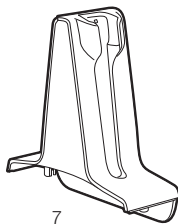
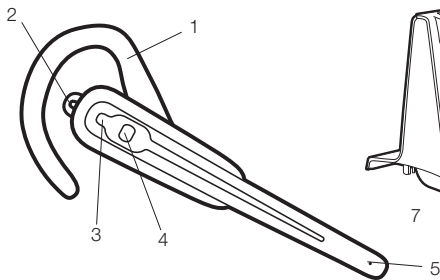

1. Earloop
2. Alça de ouvido
3. Luz indicadora
4. Botão de controle de chamadas (também controla as funções de volume, mudo e alternância)
5. Microfone
6. Alça
7. Base de carga
8. Alça de ouvido extra
9. Almofadas de espuma para o ouvido



# Bem-vindo

Parabéns por adquirir o seu novo produto da Plantronics. Este guia rápido de instruções o ajudará a configurar o sistema de headset sem fio Savi Office WO100 (Base WO1™ + HeadsetWH100/WH110™). Consulte o folheto [Instruções sobre Segurança](#) para obter informações importantes de segurança do produto antes da instalação ou do uso do produto.

## Requisitos de sistema

Os requisitos mínimos de sistema para o Savi Office são os seguintes:

- Sistemas operacionais suportados: Windows XP, Windows Vista
- Processador: processador Pentium de 400 MHz ou equivalente (mínimo); processador Pentium de 1GHz ou equivalente (recomendado)
- RAM: 96 MB (mínimo); 256 MB (recomendado)
- Disco rígido: 280 MB (mínimo); 500 MB (recomendado)
- Visor: 800 x 600, 256 cores (mínimo); cores de alta resolução de 1024 x 768, 32 bits (recomendado)
- Internet Explorer 6.0 ou superior (necessário)

**Recomendamos que você consulte o CD com instruções interativas de configuração e o Guia do Usuário.**

## Instruções de Segurança

 Não use fones de ouvido/headsets em volume muito alto por períodos prolongados de tempo. Isso pode causar a perda de audição. Ouça sempre em níveis moderados. Visite [www.plantronics.com/healthandsafety](http://www.plantronics.com/healthandsafety) para mais informações sobre headsets e assuntos de audição.

# Configurando o sistema Savi Office WO100

## 1. Conectando a base de carga à base

Conecte a base de carga do headset à base. Empurre firmemente a base até que ela se encaixe e fique no lugar.

## 2. Conectando a base ao telefone de mesa

- 2-1. Conecte o cabo de interface do telefone à entrada do cabo de interface na base.
- 2-2. Após desconectar o cabo espiral do monofone do telefone de mesa, conecte o cabo de interface do telefone na porta, agora aberta, do monofone, no telefone de mesa.
- 2-3. Conecte o cabo espiral do monofone à caixa de junção do cabo de interface do telefone.

## 3. Conectando a fonte de alimentação à base

- 3-1. Conecte a fonte de alimentação da base na entrada de energia da base.
- 3-2. Conecte a fonte de alimentação à tomada.

## 4. Encaixando e recarregando o headset

Empurre levemente o headset para a base de carga. Carregue por, no mínimo, 20 minutos antes de usar pela primeira vez. Uma carga completa leva 3 horas.



## 5. Verificando a configuração

- 5-1. Ajuste o volume do telefone de mesa para um nível médio.
- 5-2. Na base, certifique-se de que a chave de configuração esteja definida para "A" e que os volumes de fala e de audição do telefone estejam definidos para 3.

**OBSERVAÇÃO** para a maioria dos telefones, as configurações padrões de fábrica são as melhores.

- 5-3. Com o seu headset ligado, pressione o botão de controle de chamadas do headset.
- 5-4. Remova o monofone da base do telefone de mesa.

- 5-5. Ouça um tom de discagem. Se o tom de discagem for claro, pressione o botão de controle de chamadas do headset e continue no [Passo 6. Fazendo uma chamada teste com o telefone de mesa.](#)
- 5-6. Se o tom de chamada soar muito alto ou muito suave, ajuste o volume do headset.
- 5-7. Se o tom de discagem não soar claro, ajuste a chave de configuração até que ele atinja o som ideal.

**OBSERVAÇÃO** Diversas configurações podem funcionar com o seu telefone; no entanto, apenas uma será a posição ideal.

- 5-8. Pressione o botão de controle de chamadas do headset e retorne o monofone à base para concluir a configuração.

## 6. Fazendo uma chamada teste com o telefone de mesa

- 6-1. Com o seu headset ligado, pressione o botão de controle de chamadas do headset.
- 6-2. Remova o monofone da base do telefone de mesa.
- 6-3. Disque o número usando o seu telefone de mesa.
- 6-4. Se necessário, ajuste o volume de audição do headset.
- 6-5. Se o volume de audição do telefone de mesa ainda estiver muito alto ou muito suave, ajuste-o na base.
- 6-6. Se o volume de fala estiver muito alto ou muito suave para o receptor, ajuste o volume de fala do telefone na base.
- 6-7. Pressione o botão de controle de chamadas do headset e retorne o monofone à base para concluir a chamada teste.

## 7. Conectando ao PC

- 7-1. Conecte o cabo USB na porta USB da parte traseira da base.
- 7-2. Conecte a outra extremidade do cabo USB na porta USB do PC.
- 7-3. Insira o CD e instale o software PerSono Suite. Siga as instruções de instalação exibidas em seu computador.

## 8. Fazendo uma chamada teste com o computador

- 8-1. Verifique se o software PerSono Suite está em execução no seu computador.
- 8-2. Com o headset ligado, pressione o botão de conversação do computador na base.
- 8-3. Disque um número usando o aplicativo do seu softphone
- 8-4. Ajuste os volumes de fala e audição usando o aplicativo do seu softphone e/ou na opção "Sons e Dispositivos de Áudio" no Painel de Controle do seu computador.
- 8-5. Você pode ajustar da melhor forma o volume de audição no headset.
- 8-6. Para finalizar a chamada teste, pressione o botão de controle de chamadas no headset.

Consulte o Guia de Usuário, que está no CD, para obter mais detalhes de como usar o seu sistema de headset wireless profissional do Savi Office WO100.

## Homologação Anatel

Este produto está homologado pela ANATEL, de acordo com os procedimentos regulamentados pela resolução 242/2000, e atende aos requisitos técnicos aplicados.

Para maiores informações consulte o site da ANATEL.

<http://www.anatel.gov.br>



0647-09-1893



( 0 1 ) 0 7 8 9 8 4 0 1 7 1 0 6 1 0

" ESTE EQUIPAMENTO OPERA EM CARÁTER SECUNDÁRIO. ISTO É, NÃO TEM DIREITO A PROTEÇÃO CONTRA INTERFERÊNCIA PREJUDICIAL, MESMO DE ESTAÇÕES DO MESMO TIPO E NÃO PODE CAUSAR INTERFERÊNCIA A SISTEMAS OPERANDO EM CARÁTER PRIMÁRIO. "

Distribuído por Plantronics Telecomunicações Ltda  
CNPJ 05.758.913/0001-95



This device complies with Part 15 of the FCC Rules. Operation is subject to the following two conditions:

1. This device may not cause harmful interference, and
2. This device must accept any interference received, including interference that may cause undesired operation.

This equipment has been tested and found to comply with the limits for a Class B digital device, pursuant to Part 15 of the FCC Rules. These limits are designed to provide reasonable protection against harmful interference in a residential installation. This equipment generates, uses, and can radiate radio frequency energy and, if not installed and used in accordance with the instructions, may cause harmful interference to radio communications. However, there is no guarantee that interference will not occur in a particular installation. If this equipment does cause harmful interference to radio or television reception which can be determined by turning the radio or television off and on, the user is encouraged to try to correct interference by one or more of the following measures:

1. Reorient or relocate the receiving antenna.
2. Increase the separation between the equipment and receiver.
3. Connect the equipment into an outlet on another circuit.
4. Consult the dealer or an experienced radio/TV technician for help.

#### FCC REGISTRATION INFORMATION — Part 68

This equipment complies with Part 68 of the FCC rules and the requirements adopted by ACTA. On the exterior of this equipment is a label that contains a product identifier in the format US:AAAEQ##TXXXX. If requested, this information must be provided to your telephone company.

A plug and jack used to connect this equipment to the premises wiring and telephone network must comply with the applicable FCC Part 68 rules and requirements adopted by ACTA. A compliant telephone cord and modular plug is provided with this product. It is designed to be connected to a compatible jack that is also compliant. See installation instructions for details.

The REN is useful to determine the quantity of devices you may connect to your telephone line. Excessive RENs on a telephone line may result in the devices not ringing in response to an incoming call. In most, but not all areas, the sum of the RENs should not exceed five (5.0). To be certain of the number of devices you may connect to your line, as determined by the REN, contact your local telephone company. For products approved after August 8, 2001, the REN for this product is part of the product identifier that has the format US:AAAEQ##TXXXX. The digits represented by ## are the REN without the decimal point. (For example, 03 represents a REN of 0.3.) For earlier producers, the REN is separately shown on the label.

If this telephone equipment causes harm to the telephone network, the telephone company will notify you in advance that temporary discontinuance of service may be required. But if advance notice isn't practical, the telephone company will notify the customer as soon as possible. Also, you will be advised of your right to file a complaint with the FCC if you believe it is necessary.

The telephone company may make changes in its facilities, equipment, operations, or procedures that could affect the proper functioning of your equipment. If they do, you will be notified in advance in order for you to make necessary modifications to maintain uninterrupted service.

If trouble is experienced with this unit, for repair or warranty information, please contact customer service at (800) 544-4660. If the equipment is causing harm to the network, the telephone company may request that you disconnect the equipment until the problem is resolved.

**DO NOT DISASSEMBLE THIS EQUIPMENT:** It does not contain any user-serviceable components.

We recommend the installation of an AC surge arrester in the AC outlet to which this equipment is connected. Telephone companies report that electrical surges, typically lightning transients, are very destructive to customer terminal equipment connected to AC power sources.

Exposure to RF Radiation

The internal wireless radio operates within the guidelines found in radio frequency safety standards and recommendations, which reflect the consensus of the scientific community. Independent studies have shown that the internal wireless radio is safe for use by consumers. Visit [www.plantronics.com](http://www.plantronics.com) for more information.

In order to comply with FCC RF Exposure requirements, the base must be installed and operated such that a minimum separation distance of 20 cm is maintained between the base and all persons during normal operation.

NOTE: Modifications not expressly approved by Plantronics, Inc. could void the user's authority to operate the equipment.

#### INDUSTRY CANADA REGULATORY INFORMATION

This product meets the applicable Industry Canada technical specifications/Le présent matériel est conforme aux spécifications techniques applicable d' Industrie Canada.

This Class B digital apparatus complies with Canadian ICES-003.

Cet appareil numérique de la classe B est conforme à la norme NMB-003 du Canada.

Plantronics, Inc.

345 Encinal Street

Santa Cruz, CA 95060

United States

Tel: 800-544-4660

Tel: 831-426-5858

[www.plantronics.com](http://www.plantronics.com)



©2009 Plantronics, Inc. All rights reserved. Plantronics, the logo design, PerSono, Savi, and Sound Innovation are trademarks or registered trademarks of Plantronics, Inc. All other trademarks are the property of their respective owners.

Patents US 5,210,791; D469,756; Australia 147229; France 651,857-651,865; Germany 40108524.4; GB Regd.Des.No. 2104923;

Patents Pending..

82328-03 (12.09)